

**LOCATION:** NW 32nd Ave -- NW Lower River Rd  
**CITY/STATE:** Vancouver, WA

**QC JOB #:** 14747822  
**DATE:** Tue, Aug 14 2018

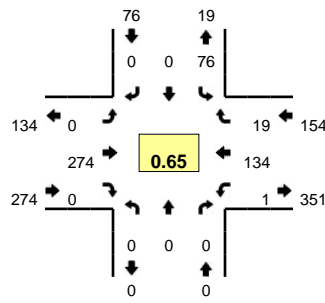

**Peak-Hour: 3:25 PM -- 4:25 PM**  
**Peak 15-Min: 4:00 PM -- 4:15 PM**

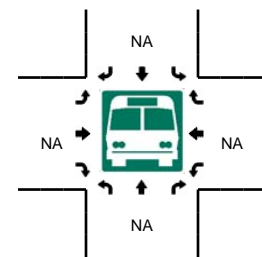
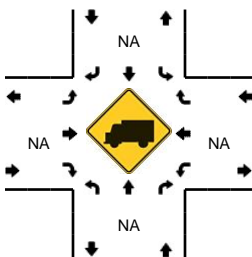
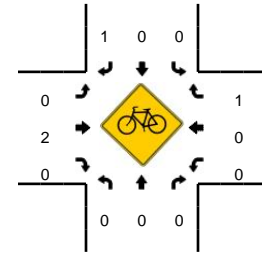
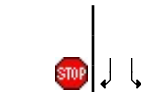
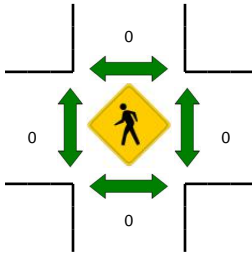
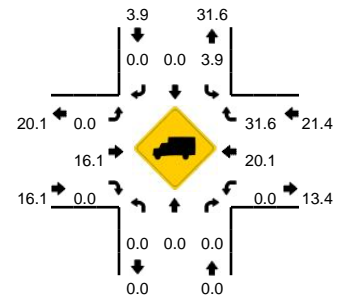

5-Min Count Period Beginning At	NW 32nd Ave (Northbound)				NW 32nd Ave (Southbound)				NW Lower River Rd (Eastbound)				NW Lower River Rd (Westbound)				Total	Hourly Totals	
	Left	Thru	Right	U	Left	Thru	Right	U	Left	Thru	Right	U	Left	Thru	Right	U			
3:00 PM	0	0	0	0	1	0	0	0	0	7	0	0	0	0	20	4	0	32	
3:05 PM	0	0	0	0	2	0	0	0	0	30	0	0	0	0	9	2	0	43	
3:10 PM	0	0	0	0	1	0	0	0	0	26	0	0	0	0	9	0	0	36	
3:15 PM	0	0	0	0	3	0	0	0	0	22	0	0	0	0	12	0	0	37	
3:20 PM	0	0	0	0	0	0	0	0	0	24	0	0	0	0	14	0	0	38	
3:25 PM	0	0	0	0	5	0	0	0	0	14	0	0	0	0	12	3	0	34	
3:30 PM	0	0	0	0	17	0	0	0	0	21	0	0	0	0	10	1	0	49	
3:35 PM	0	0	0	0	10	0	0	0	0	17	0	0	0	0	19	1	0	47	
3:40 PM	0	0	0	0	3	0	0	0	0	12	0	0	0	0	12	2	0	29	
3:45 PM	0	0	0	0	2	0	0	0	0	14	0	0	0	0	7	0	0	23	
3:50 PM	0	0	0	0	2	0	0	0	0	8	0	0	0	0	9	2	0	21	
3:55 PM	0	0	0	0	5	0	0	0	0	11	0	0	0	0	12	1	0	29	418
4:00 PM	0	0	0	0	13	0	0	0	0	22	0	0	0	0	10	1	0	46	432
4:05 PM	0	0	0	0	7	0	0	0	0	59	0	0	0	0	15	2	0	83	472
4:10 PM	0	0	0	0	4	0	0	0	0	52	0	0	0	0	8	0	0	64	500
4:15 PM	0	0	0	0	3	0	0	0	0	21	0	0	0	0	11	3	0	38	501
4:20 PM	0	0	0	0	5	0	0	0	0	23	0	0	0	0	9	3	1	41	504
4:25 PM	0	0	0	0	1	0	0	0	0	14	0	0	0	0	12	2	0	29	499
4:30 PM	0	0	0	0	3	0	0	1	0	13	0	0	0	0	11	1	0	29	479
4:35 PM	0	0	0	0	3	0	0	1	0	18	0	0	0	0	7	1	0	30	462
4:40 PM	0	0	0	0	5	0	0	0	0	17	0	0	0	0	7	0	0	29	462
4:45 PM	0	0	0	0	6	0	0	0	0	12	0	0	0	0	11	0	0	29	468
4:50 PM	0	0	0	0	3	0	0	0	1	11	0	0	0	0	8	0	0	23	470
4:55 PM	0	0	0	0	2	0	0	0	0	7	0	0	0	0	14	1	0	24	465
Peak 15-Min Flowrates	Northbound				Southbound				Eastbound				Westbound				Total		
	Left	Thru	Right	U	Left	Thru	Right	U	Left	Thru	Right	U	Left	Thru	Right	U			
All Vehicles	0	0	0	0	96	0	0	0	0	532	0	0	0	0	132	12	0	772	
Heavy Trucks	0	0	0	0	0	0	0	0	0	28	0	0	0	0	20	4	0	52	
Pedestrians	0	0	0	0	0	0	0	0	0	0	0	0	0	0	0	0	0	0	
Bicycles	0	0	0	0	0	0	1	0	0	1	0	0	0	0	0	0	0	2	
Railroad																			
Stopped Buses																			

Comments: